

GPI65030TO5L

N-channel 650V 30A GaN Power HEMT in TO263-5L Package

Datasheet version: 1.5

Features

BV_{dss}	R_{dson}	I_{ds}	Q_g
700 V	55 m Ω	30 A	5.8 nC

- Ultra-low $R_{DS(on)}$
- High dv/dt capability
- Extremely low input capacitance
- Zero Q_{rr}
- Outstanding switching performance
- Low Profile

Applications

- Switching Power Applications
- Adapters, Quick Chargers

Description

These devices are N-channel 650 V Power GaN HEMTs based on proprietary E-mode GaN on silicon technology. The resulting product has extremely low on state resistance, very low input capacitance and zero reverse recovery charge making it especially suitable for applications which require superior power density, ultra-high switching frequency and outstanding efficiency.

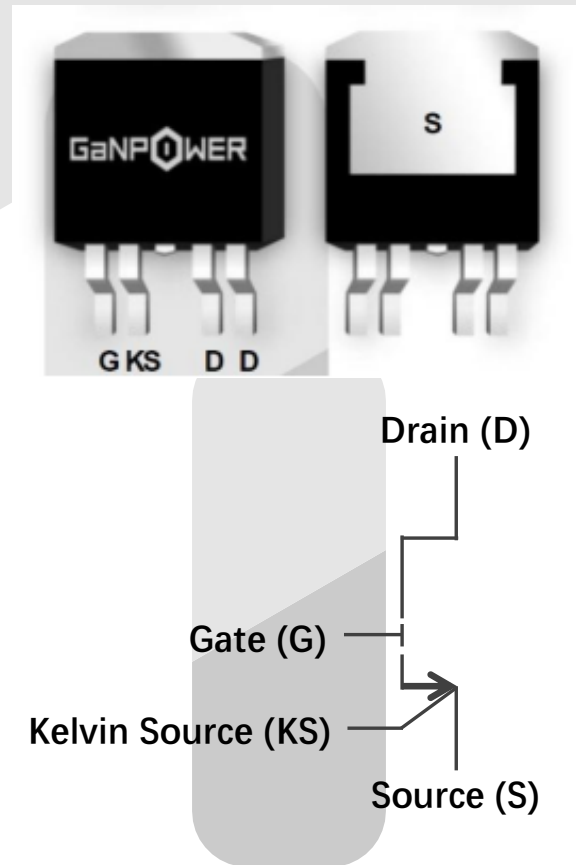



GaNPower International Inc.

WWW.IGANPOWER.COM
 230 -3410 LOUGHEED HWY
 VANCOUVER, BC, V5M 2A4 CANADA

Device Characteristics

Static Parameters				Test data			
	Parameters		Conditions	Min	Typical	Max	Unit
1	$V_{gs(TH)}$	Gate threshold voltage	$V_{ds}=V_{gs}$ $I_d=21mA$	0.9	1.2	2.9	V
2	BV_{dss}	Drain-Source breakdown voltage	$V_{gs}=0V$ $I_d<50uA$		700		V
3	I_{dss}	Zero gate voltage drain current, $T_c = 25\text{ }^\circ\text{C}$	$V_{gs}=0V$ $V_{ds}=650V$		2.2	50	μA
4	I_{gss}	Gate-Source Leakage	$V_{gs} = 6V$ $V_{ds} = 0V$		0.3	3	mA
5	R_{dson}	Static drain-source on resistance, $T_c = 25\text{ }^\circ\text{C}$	$V_{gs}=6V$ $I_d=6A$	29	55	70	m Ω
6	V_{sd}	Reverse conduction voltage	$I_{sd}=0.8A$ $V_{gs}=0V$	1.5	1.85	3.0	V
7	R_g	Gate resistance	$F=25MHz$		1.2		Ω
Dynamic Parameters				Test data			
	Parameters		Conditions	Min	Typical	Max	Unit
1	C_{iss}	Input capacitance	$V_{gs}=0V$		241		pf
	C_{oss}	Output capacitance	$V_{ds}=400V$		61		pf
	C_{rss}	Reverse transfer capacitance	$f=1MHz$		8.4		pf
3	Q_g	Gate charge	$V_{ds}=400V$		5.8		nC
	Q_{gs}	Gate to source charge	$I_d=7.5A$		1.2		nC
	Q_{gd}	Gate to drain charge	$V_{gs}=6V$		1.5		nC
2	Q_{rr}	Reverse recovery charge			0		nC
Switching Performance				Test data			
	Parameters		Conditions	Min	Typical	Max	Unit
1	$t_{d(on)}$	Turn-on delay time	$V_{ds}=400V$		6		ns
2	t_r	Rise time	$I_d=2.5A$		12		ns
3	$t_{d(off)}$	Turn-off delay time	$R_g=10\Omega$		15		ns
4	t_f	Fall time	$V_{gs}=6V$		13		ns



GaNPower International Inc.

WWW.IGANPOWER.COM
230 -3410 LOUGHEED HWY
VANCOUVER, BC, V5M 2A4 CANADA

Absolute Max. Ratings

	Symbols	Parameters	Value	Unit
1	V_{DS-max}	Breakdown voltage transient @ $T_{case}=25^{\circ}C$	800	V
2	V_{GS-max}	Gate to source max. voltage @ $T_{case}=25^{\circ}C$	-12 to +7.5	V
3	I_{ds-max}	Drain to source DC current @ $T_{case}=25^{\circ}C$	30	A
4	I_{ds-max}	Drain to source DC current @ $T_{case}=100^{\circ}C$	24	A
5	dv/dt_{max}	Drain to source voltage slew rate	200	V/nS
6	T_{J-max}	Max junction temperature	150	$^{\circ}C$
7	$T_{S-storage}$	Storage temperature	-55 to 150	$^{\circ}C$

Thermal and Soldering Characteristics (Typical)

	Symbols	Parameters	Value	Unit
1	R_{thJC}	Thermal resistance (junction to case)	0.95	$^{\circ}C /W$
2	T_{solder}	Reflow soldering temperature	250	$^{\circ}C$

Ordering

Order Code	Package Type	Packaging Method	Qty
GPI65030TO5L		Tape and Reel	

Electrical Performance

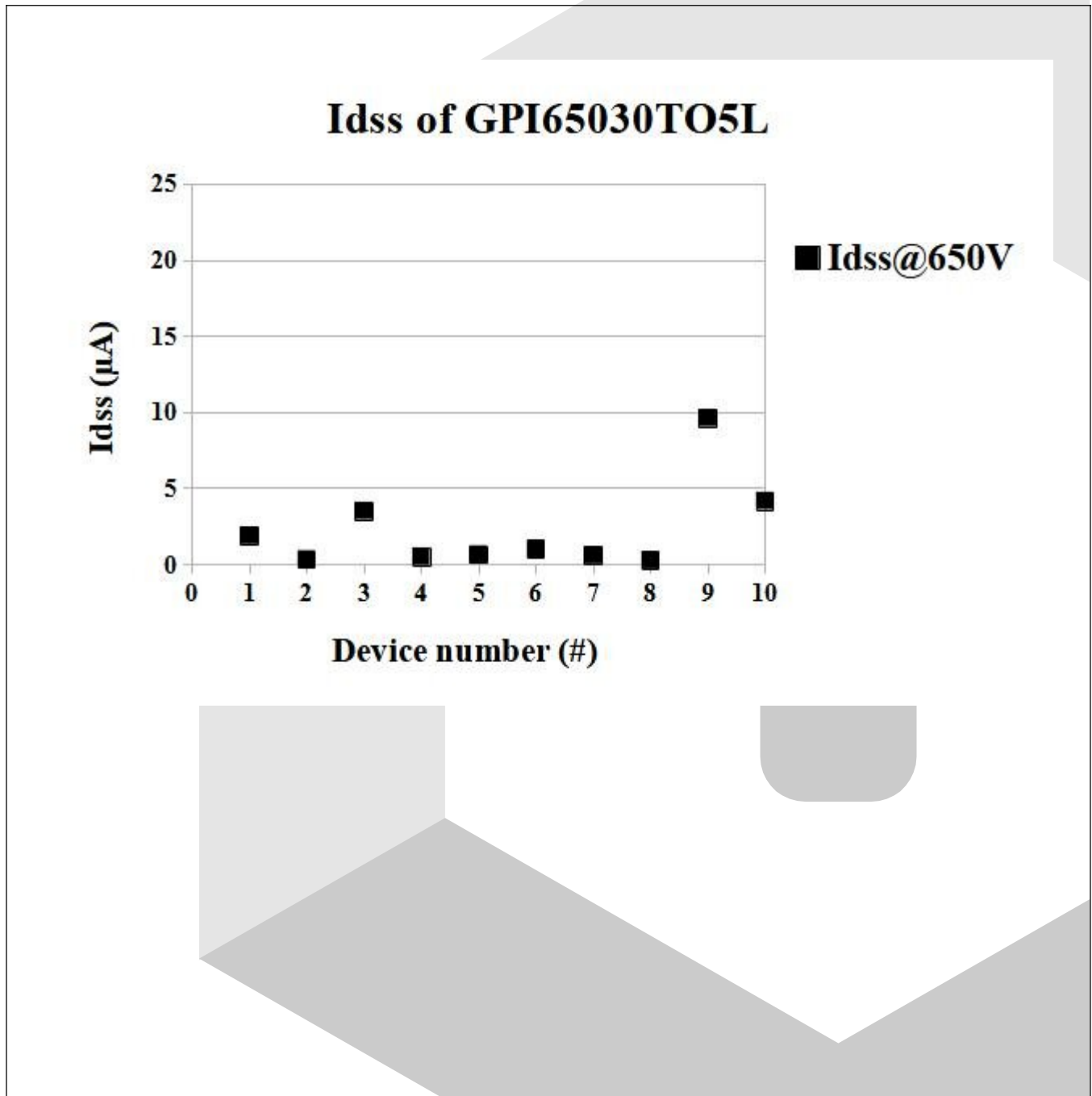



GaNPower International Inc.

WWW.IGANPOWER.COM
230 -3410 LOUGHEED HWY
VANCOUVER, BC, V5M 2A4 CANADA

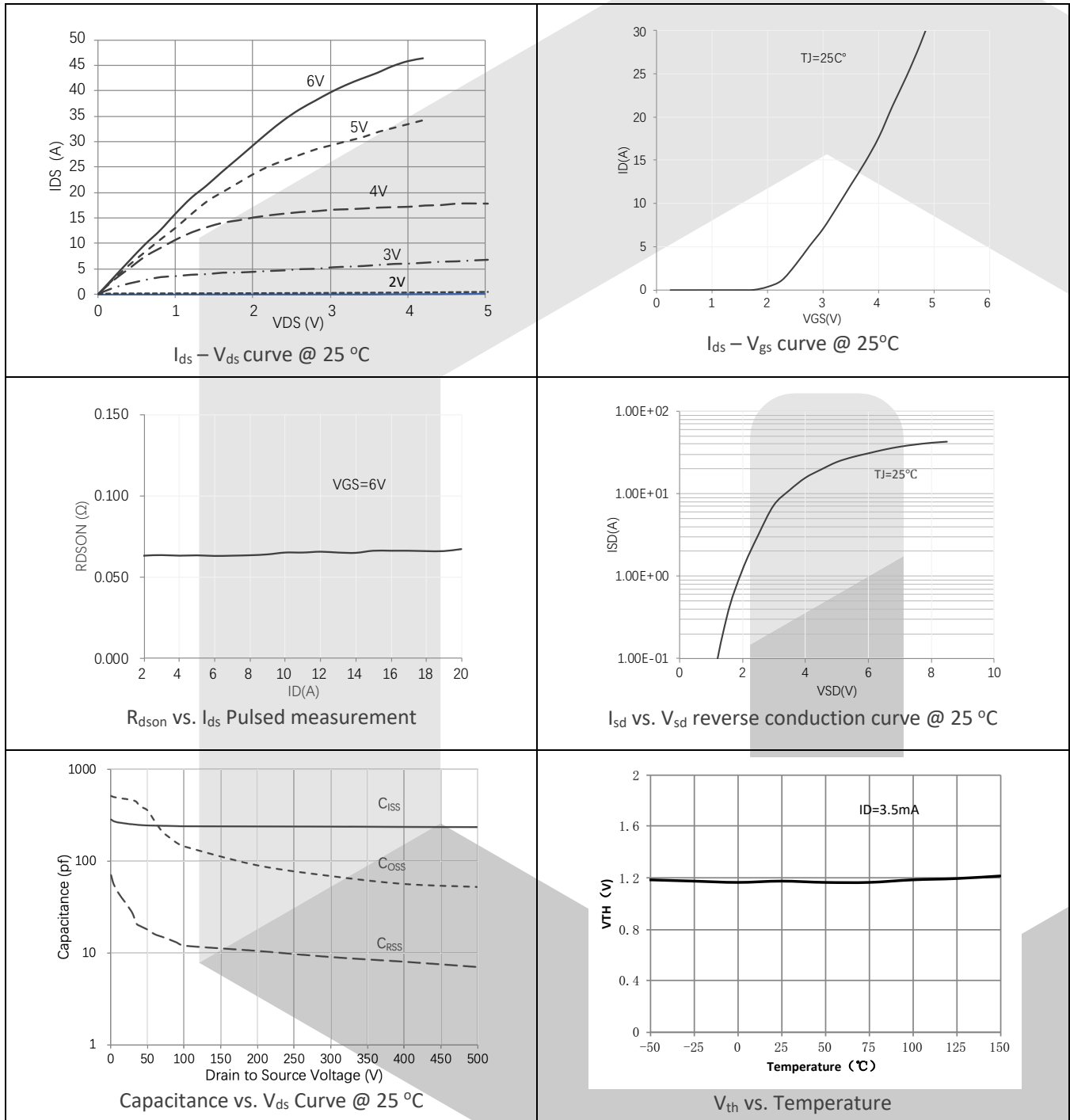



GaNPower International Inc.

WWW.IGANPOWER.COM
230 -3410 LOUGHEED HWY
VANCOUVER, BC, V5M 2A4 CANADA

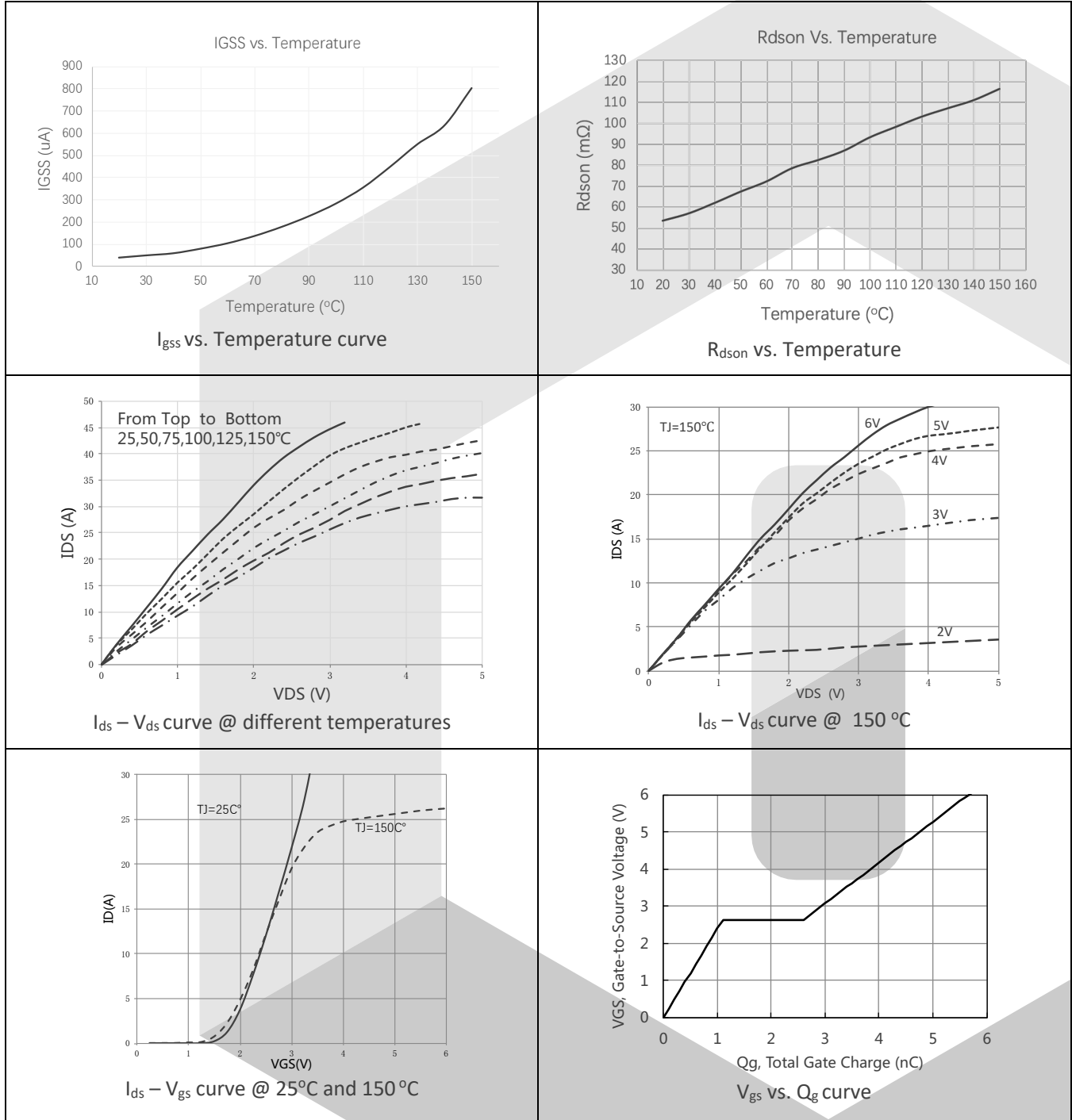

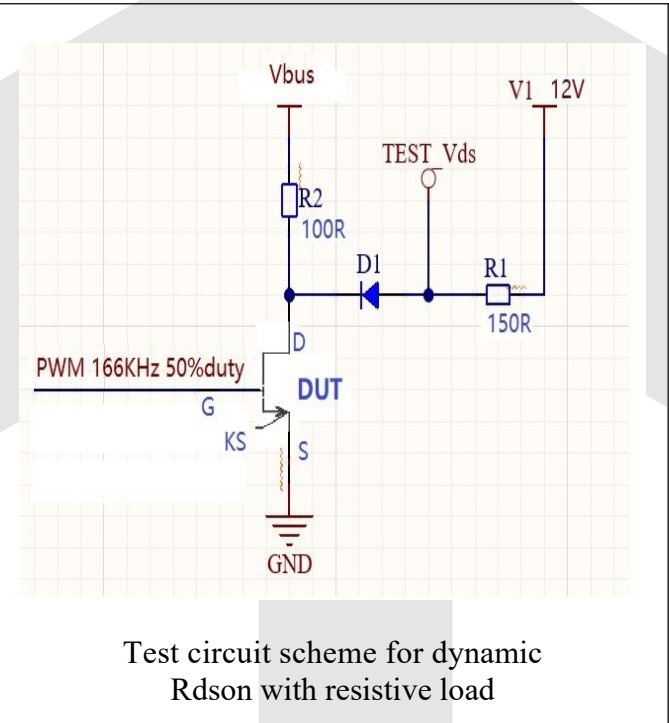
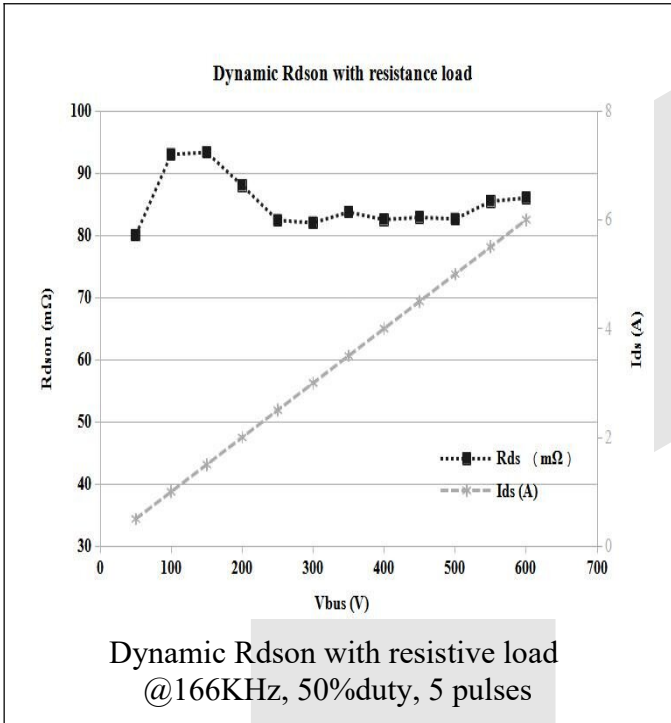

Package Information

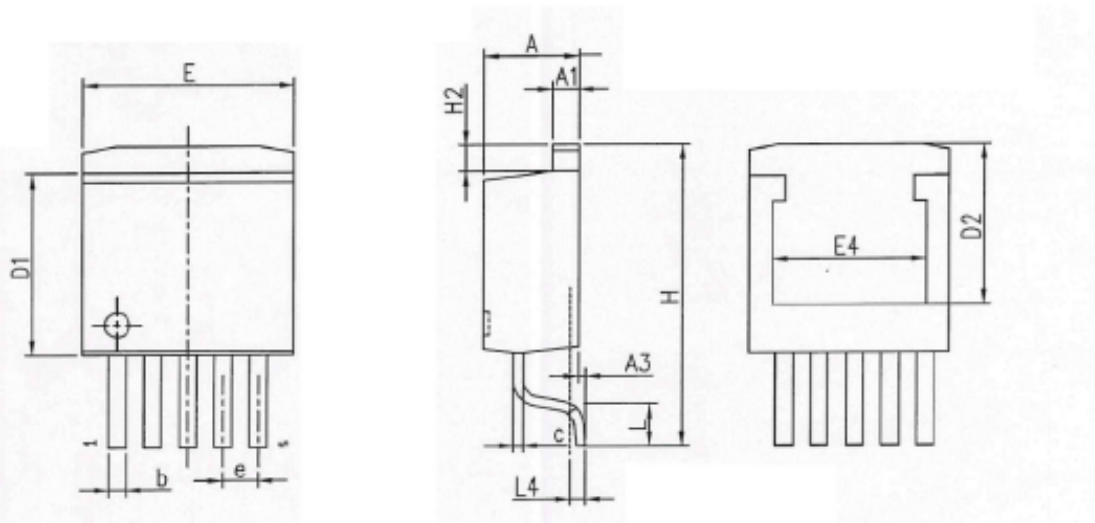
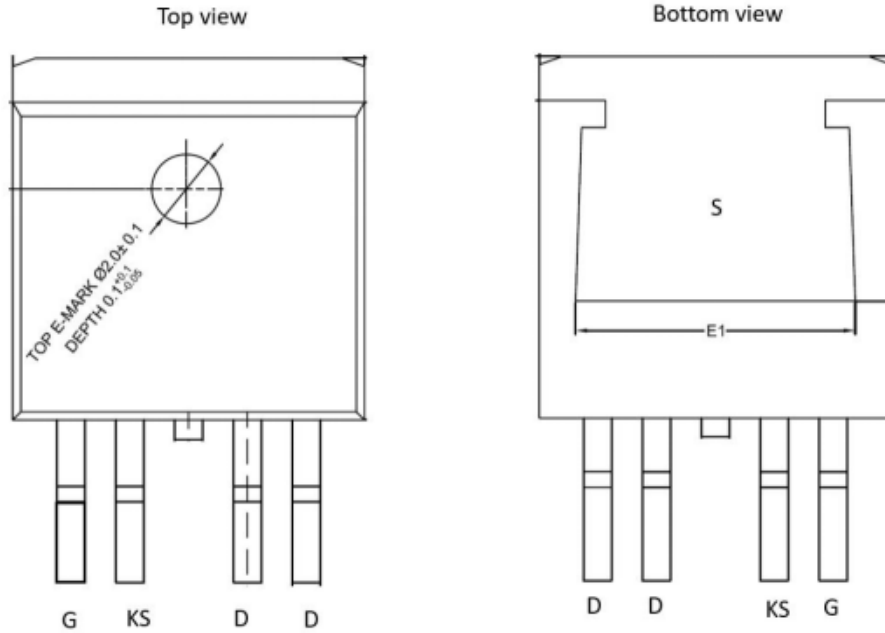

COMMON DIMENSIONS

SYMBOL	MM		
	MIN	NOM	MAX
A	4.37	4.57	4.77
A1	1.17	1.27	1.42
A3	0	-	0.25
b	0.71	-	0.97
c	0.33	-	0.76
D1	8.38	8.70	9.00
D2	6.00	-	-
E	9.90	10.16	10.39
E4	7.30	-	-
e	1.70BSC		
H	-	-	14.35
H2	-	-	1.27
L	-	1.98	-
L4	-	0.76	-



GaNPower International Inc.

WWW.IGANPOWER.COM
230 -3410 LOUGHEED HWY
VANCOUVER, BC, V5M 2A4 CANADA

Further Information

Important Notice-Unless expressly approved in writing by an authorized representative of GaNPower, GaNPower components are not designed, authorized or warranted for use in lifesaving, life sustaining, military, aircraft, or space applications, nor in products or systems where failure or malfunction may result in personal injury, death, or property or environmental damage. The information given in this document shall not in any event be regarded as a guarantee of performance. GaNPower hereby disclaims any or all warranties and liabilities of any kind, including but not limited to warranties of non-infringement of intellectual property rights. All other brand and product names are trademarks or registered trademarks of their respective owners. Information provided herein is intended as a guide only and is subject to change without notice. The information contained herein or any use of such information does not grant, explicitly, or implicitly, to any party any patent rights, licenses, or any other intellectual property rights. All rights reserved.

Data Source– Data here are based on recent tests but all parameters may not be up to date. Actual final test data from packaging production are available for selected customers upon request.